

INDOOR ARENA WALL

Safety Wall



The COLUMBUS indoor arena wall "Safety Wall" – an innovation from plastic



Safety and durability are the two main features of our **Safety Wall**, because the safety of horses and riders very important to us and we think that equipment for equine facilities need to be practical and durable.

All equine facilities have to keep up with safety regulations for indoor arenas. You are on the safe side with the **Safety Wall**.

The **Safety Wall** is impact-resistant and absorbs ever type of impact. The surface is smooth and available in every RAL colour.

By using an especially developed plastic we can almost preclude any damage to the wall. The indoor arena wall is of course waterproof and can be cleaned by simply hosing the dust off. There is no risk of rotting, which makes this arena wall a very efficient and long lasting investment.



INDOOR ARENA WALL

Safety Wall



The **Safety Wall** is:

- waterproof
- impact-resistant
- shock absorbing
- in every RAL colour available
- easy to assemble

The **Safety Wall** has:

- 5 years warranty (carry in basis)
- smooth surface
- rounded edges

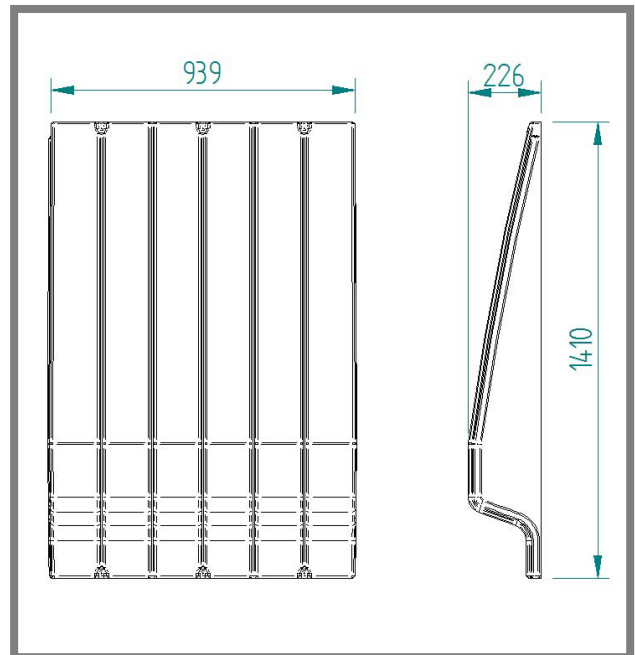

An exceptional door system

Columbus has developed a revolte joint hinge for the **Safety Wall** which allows the door to open horizontally just like a normal door. The hinge is completely integrated into the wall. This way not only the hinge is invisible but also the door when it is closed. Due to that you get an ideally finished wall for your indoor arena.

You might know the problem with opening doors which are fixed to a slanted indoor arena wall. That is why our revolte joint hinges are also available individually. You can easily fix our joints to your indoor arena door.

The **Safety Wall** revolte joint is a great solution!

